

# ZANUSSI

The Electrolux logo consists of a blue square icon with a white stylized 'E' inside, followed by the word 'Electrolux' in a blue, sans-serif font. A blue curved line arches over the logo.

**Electrolux**

FRIDGE - FREEZER

ZNB 404 W  
ZNB 404 S

**INSTRUCTION BOOK**

GB

**This instruction book contains safety precautions, information on use and helpful hints and tips.**

**To ensure you use this appliance effectively and safely, please read this instruction book carefully before installing or using this appliance and retain for future reference.**

The symbols below help you to find things more easily:



**Safety precautions**

Warnings and Safety information



**Hints, useful information**



**Environmental information**



The symbol on the product or on its packaging indicates that this product may not be treated as household waste. Instead it should be handed over to the appropriate collection point for the recycling of electrical and electronic equipment. By ensuring this product is disposed of correctly, you will help prevent potential negative consequences for the environment and human health, which could otherwise be caused by inappropriate waste handling of this product. For more detailed information about recycling of this product, please contact your local council, your household waste disposal service or the shop where you purchased the product.

# IMPORTANT SAFETY INSTRUCTIONS

These warnings are provided in the interests of your safety. Ensure that you understand them all before installing or using this appliance. Your safety is of paramount importance. If you are unsure about any of the meanings or these warnings contact the Customer Care Department.

## Prior to installation

- Check the appliance for transport damage. Under no circumstances should a damaged appliance be installed. In the event of damage please contact your retailer.

## Installation

- This appliance is heavy. Care should be taken when moving it.
- It is dangerous to alter the specifications or attempt to modify this product in any way.
- Ensure that the appliance does not stand on the electrical supply cable. If the supply cable is damaged, it must be replaced by a cable available from your local Service Force Centre.
- **Make sure that the power plug has not been squashed or damaged during transit.**
  - A damaged power plug may overheat and cause a fire.
- **As you unpack the appliance, check carefully for any signs of transit damage.**
- **Do not place heavy articles or the fridge/freezer itself on the power cord.**
  - There is a risk of a short circuit and fire.
- **Do not remove the power cord by pulling on its lead, particularly when the fridge/freezer is being pulled out of its niche.**
  - Damage to the cord may cause a short-circuit, fire and/or electric shock.
  - If the power cord is damaged, it must be replaced by a certified service agent or qualified service personnel.
- **If the power plug socket is loose, do not insert the power plug.**
  - There is a risk of electric shock or fire.
- Any electrical work required to install this appliance should be carried out by a qualified electrician or competent person.
- Parts which heat up should not be exposed. Whenever possible, the back of the appliance should be close to a wall, but leaving the required distance for ventilation, as stated in the installation instructions.
- The appliance should be left for 2 hours after installation before it is turned on, in order to allow the refrigerant to settle.

## Child Safety

- Do not allow children to tamper with the controls or play with the product.
- Keep packaging materials away from children to prevent the risk of suffocation!
- This appliance is not intended for use by persons (including children) with reduced physical, sensory or mental capabilities, or lack of experience and knowledge, unless they have been given supervision or instruction concerning use of the appliance by a person responsible for their safety.

Children should be supervised to ensure that they do not play with the appliance.

## Safety precautions for isobutane

### Warning

- The refrigerant isobutane (R 600a) is contained within the refrigerant circuit of the appliance, a natural gas with a high level of environmental compatibility, which is nevertheless flammable.

- Keep ventilation openings, in the appliance enclosure or in the built-in structure, clear of obstruction.
- Do not use mechanical devices or other means to accelerate the defrosting process, other than those recommended by the manufacturer.
- Do not damage the refrigerant circuit.
- Do not use electrical appliances inside the food storage compartments of the appliance.

## During Use

- This appliance is designed for domestic use only, specifically for the storage of edible foodstuffs. It is not intended for commercial or industrial use.
- Containers with flammable gases or liquids can leak at low temperatures. Do not store any containers with flammable materials, such as spray cans, fire extinguisher refill cartridges etc. in the appliance.
- Frozen food should not be refrozen once it has thawed out.
- Do not place carbonated or fizzy drinks in the freezer compartment.
- Ice lollies can cause 'frost/freezer burns' if consumed straight from the freezer.
- Do not remove items from the freezer compartment if your hands are damp/wet, as this could cause skin abrasions or frost/freezer burns.
- Bottles and cans must not be placed in the freezer compartment they can burst when the contents freeze.
- Manufacturers' recommended storage times should be adhered to. Refer to relevant instructions.

## Maintenance and Cleaning

- Before cleaning, always switch off the appliance and disconnect from the electrical supply.
- When unplugging always pull the plug from the mains socket, do not pull on the cable.

## Servicing

- This product should be serviced by an authorised engineer and only genuine spare parts should be used.
- Under no circumstances should you attempt to repair the appliance yourself. Repairs carried out by inexperienced persons may cause injury or serious malfunctioning. Contact your local Service Force Centre.

## At the end of the Appliance Life

- When disposing of your appliance use an authorised disposal site.
- Remove the plug and ensure that any locks or catches are removed, to prevent young children being trapped inside.



## The Appliance and the Environment

This appliance does not contain gases which could damage the ozone layer.

Avoid damaging the cooling unit.

The packaging used on this appliance marked with the  symbol is recyclable.

**Keep this instruction book for future reference and ensure it is passed on to any new owner.**

# CONTENTS

## Instructions for the User

<b>Important Safety Instructions</b>	<b>3</b>
General Information	5
Description of the Appliance	5
<b>Switch and indicator set</b>	<b>6</b>
Display background colour	7
<b>Using the Appliance</b>	<b>7</b>
Putting it into use	7
Controlling the temperature, setting	7
How to use the refrigerator	7
Drawer	8
Shopping mode	8
The Refrigerator	8
Storage Shelves	8
Storage Times	8
The Freezer	9
Freezing Fresh Food	9
Removal of freezing baskets from the freezer	10
Frozen Food Storage	10
Defrosting	10
To Make Ice Cubes	11
<b>Hints and Tips</b>	<b>12</b>
Normal Operating Sounds	12
Food Storage	12
Energy Saving Advice	12
In the Event of a Power Failure	12
<b>Maintenance and Cleaning</b>	<b>13</b>
Internal Cleaning	13
External Cleaning	13
When the Appliance is Not in Use	13
<b>Defrosting</b>	<b>13</b>
<b>To Change the Light Bulb</b>	<b>14</b>
<b>Something Not Working</b>	<b>15</b>
<b>Service and Spare Parts</b>	<b>16</b>
<b>Customer Care Department</b>	<b>16</b>
<b>Guarantee Conditions</b>	<b>17</b>

## Instructions for the Installer

<b>Technical Data</b>	<b>18</b>
<b>Installing the Appliance</b>	<b>18</b>
Transportation, Unpacking	18
Cleaning	18
Location	18
Levelling the Appliance	19
Ventilation Requirements	19
Door reversal	19
<b>Electrical Connections</b>	<b>21</b>
<b>Storage Chart</b>	<b>22</b>

# INSTRUCTIONS FOR THE USER

## General information

The official designation of the appliance is "frostfree refrigerator-freezer combination with one motor compressor and freezer placed in the lower part". The appliance has - besides the general services - a freezer with its own door and is completely separated from the other unit.

According to this the appliance is suitable for storing frozen and deep-frozen food, freezing products in quantity given in the user's instructions at home and making ice.

The appliance can meet the requirements of standards between different temperature limits according to the climate class.

The letter symbol for climate class can be found on the rating plate.

## Description of the appliance

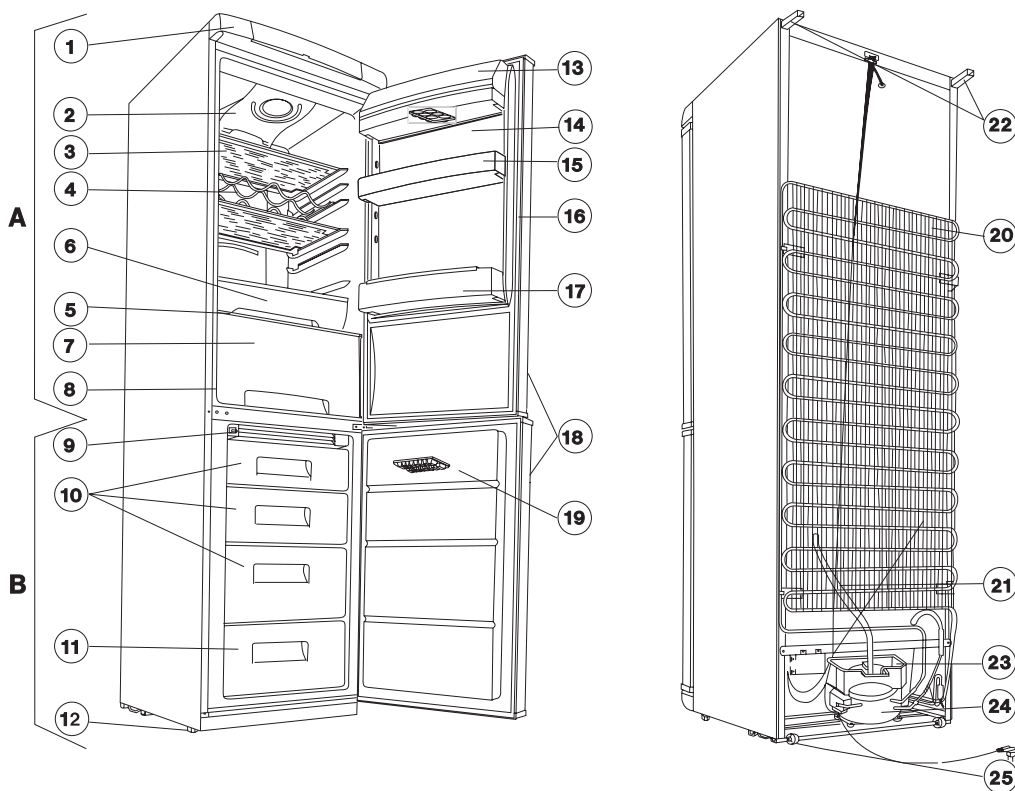

A - Refrigerator

B - Freezer

1. Top with indicating switch
2. Air distributing and lighting box
3. Glass shelves
4. Bottle rack
5. Glass shelf
6. Fresh Box
7. Drawer
8. Rating Plate
9. Air grid
10. Storing compartment(s)
11. Freezing compartment with drawer
12. Adjustable feet

13. Butter compartment lid
14. Egg tray
15. Door shelf
16. Door gasket
17. Bottle shelf
18. Handles
19. Ice tray
20. Condenser
21. Defrost water outlet tube
22. Spacer
23. Evaporator tray
24. Compressor
25. Rollers

## Switch and indicator set

The following components can be found under a cover in the top frame:

### A. Button ON/OFF

Switches the appliance on and off.

### B. Fridge temperature display

By default it shows the medium temperature inside the refrigerator. Should the temperature be higher than 9 °C, a "-" sign is shown. Should the temperature be definitely lower than 0 °C, a flashing "-" sign is shown.

It shows the desired fridge temperature by a flashing number when one of the fridge temperature setting buttons is pressed. After a while it returns to the actual temperature.

It can show an "A" symbol when the appliance in action cool mode. See also the chapter on using the refrigerator.

It can show an "H" symbol when the appliance is in holiday mode. See also the chapter on holiday mode.

### C. Fridge temperature setting button (for colder temperatures)

Press this button to make the desired fridge temperature colder by 1 °C.

### D. Fridge temperature setting button (for warmer temperatures)

Press this button to make the desired fridge temperature warmer by 1 °C.

### E. ACTION COOL button

Press this button to activate the action cool mode. See also the chapter on using the refrigerator.

### F. ACTION COOL function "on" indicator (yellow)

This indicator is lit when the appliance is in action cool mode. See also the chapter on using the refrigerator.

### G. Freezer temperature display

By default it shows the highest temperature inside the freezer.

It shows the desired fridge temperature by a flashing number when one of the freezer temperature setting buttons is pressed. After a while it returns to the actual temperature.

It can show an "A" symbol when the appliance in action freeze mode. See also the chapter on freezing.

### H. Freezer temperature setting button (for colder temperatures)

Press this button to make the desired freezer temperature colder by 1 °C.

### I. Freezer temperature setting button (for warmer temperatures)

Press this button to make the desired freezer temperature warmer by 1 °C.

### J. ACTION FREEZE button

Press this button to activate the action freeze mode. See also the chapter on freezing.

### K. ACTION FREEZE function "on" indicator (yellow)

This indicator is lit when the appliance in action freeze mode. See also the chapter on freezing.

### L. Alarm reset button

### M. Alarm light (red)

In the event of an abnormal temperature rise inside the freezer (e.g. powercut) this warning light will start to flash and a buzzer will sound.

After the temperature has returned to normal, the warning light will continue to flash, although the buzzer has stopped.

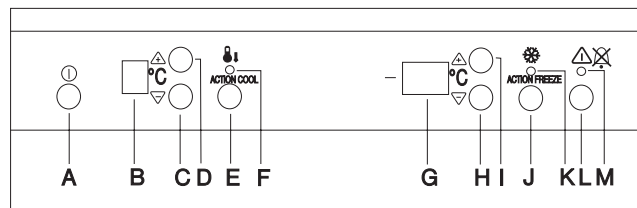
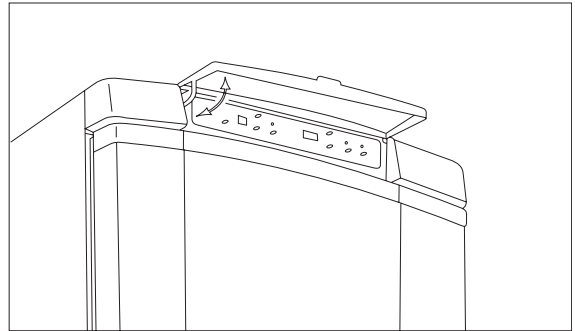

If the alarm button is pressed, the freezer temperature display shows for a few seconds the warmest temperature reached in the section. The buzzer, if sounding, will switch off.

This warning light will start to flash and a buzzer will sound in case of a door left open. To stop the alarm light simply close the door.

## Handling the appliance

### Putting it into use

Place the accessories into the appliance then plug to the mains socket.

To start the appliance, press the ON/OFF button ("A"). The fridge temperature display ("B") and freezer temperature display ("G") will go on. The alarm light ("M") flashes since the temperature is high. The buzzer sounds. To stop the buzzer, press the alarm reset button ("L").

#### Note:

The appliance cannot be switched on or off if unplugged, or if there is no power being supplied to it. Following connection to the mains power supply, the appliance returns to the same operating state as before the interruption of main power.

## Controlling the temperature, setting

The electronic control interrupts the cooling automatically for more or less time depending on the setting then restarts it assuring the required temperature.

Temperature of the refrigerator and freezer can be set by buttons "C"- "D" and "H"- "I", respectively. The desired temperature is seen blinking on the respective display.

For everyday use medium setting, i.e. +5 °C in the refrigerator and colder than -18 °C in the freezer is recommended.

Allow the appliance to run for a period of 24 hours whenever the temperature setting is changed. This will allow the temperature to stabilize inside the appliance.

The temperature in the refrigerator is affected by not only the position of the thermostat but the ambient temperature, frequency of door openings and the quantity of food put into it etc.

**i** When the coldest temperature possible is set - in case of increased demand e.g. during heatwaves - the compressor may operate continually. This does not affect the operation of the appliance.

## How to use the refrigerator

**i** For adequate cooling developing interior air circulation is necessary. For this reason you are asked not to cover the air circulation gaps behind the shelves (e.g. with tray etc.).

**i** Do not put hot food into the refrigerator. Allow it to reach room temperature naturally. In this way the unnecessary frost building up can be avoided.

**i** Foods can take over odours from each other. So it is essential to put foods in closed dishes or wrap them in cellophane, aluminium foil, grease-proof paper or cling film before placing them into the refrigerator. This way foods will keep their moisture e.g. vegetables will not dry out after some days.

## Drawer

The drawer is suitable for storing fruit and vegetables.

There is a separator inside the drawer that can be placed in different positions to allow you to separate food if required.

## ACTION COOL mode

The ACTION COOL function is suited for quick cooling of large quantities of goods in the refrigerator.

The ACTION COOL function is switched on by pressing the ACTION COOL button ("E").

The yellow light ("F") illuminates. During the time of ACTION COOL the display ("B") shows an "A" letter.

The ACTION COOL function now provides for intensive cooling. A desired temperature of +2 °C is automatically selected.

To exit from the ACTION COOL mode press the "E" button again. Should you not do so, after a while the refrigerator returns to automatic mode.

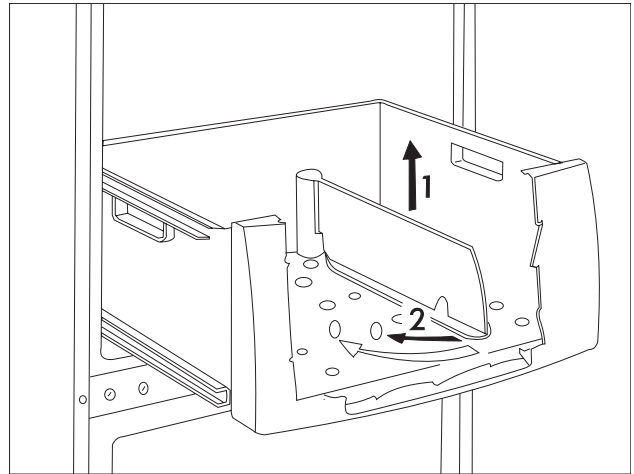

## The Refrigerator

Below is the recommended storage positions for various food types:

1. Ready-cooked foods, fresh meat, cold cuts.
2. Milk, dairy products.
3. Fruits, vegetables, salads.
4. Cheese, butter.
5. Eggs.
6. Yoghurt, sour cream.
7. Small bottles, drinks.
8. Large bottles, drinks.
9. Fish, meat, seafood

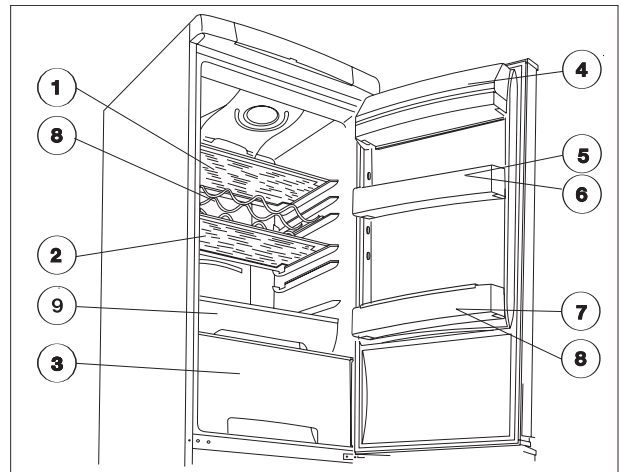

## Fresh Box

The Fresh Box is located in the fridge compartment. This is designed for the best storage of fresh food like fish, meat, seafood because the temperature is lower here than in the rest of the fridge. It is placed in the lower part, directly above of the vegetable drawer.

If you wish to remove the compartment, make sure to perform the following:

1 Open the refrigerator door as wide as possible. If due to a limit stop or any other object you cannot open the door at an angle of 180°, you should remove the bottle shelf from the door.

2 Pull the LTC compartment towards yourself and, upon reaching the end point, slightly lift the front of the drawer to remove it from the support frame.

3 For the removal of the support frame, lift the back of the frame from its nest and then pull it towards yourself. You can remove both the frame and the drawer at the same time by following Step 3.

When you want to restore the original condition, repeat above steps in reverse order.

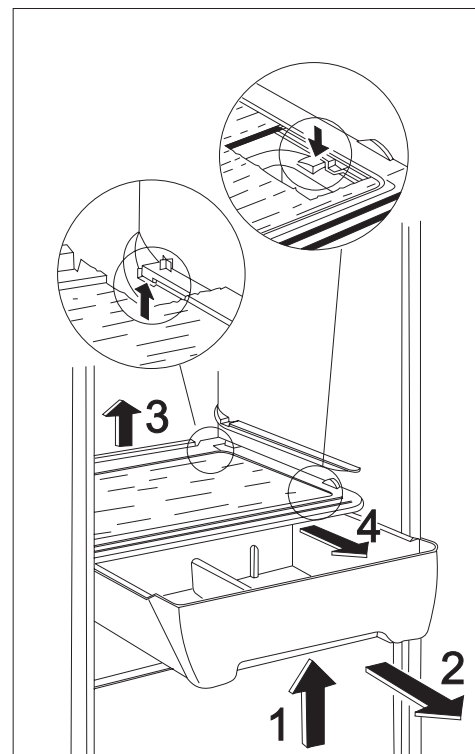



## Storage Shelves

The shelves in the refrigerator compartment are adjustable to allow for the storage of large items.

To re-arrange the shelves, open the door to 90°.

## Storage Times

The storage chart at the end of the instruction book gives information on storage times in the refrigerator compartment. The storage times quoted are intended as a guide only.

- Do not cover the shelves with paper or trays etc. as this will affect the air circulation within the refrigerator compartment.
- Do not put hot foods in the refrigerator, allow hot foods to reach room temperature naturally before placing in the refrigerator.
- Cover foods, or place in closed dishes before placing them in the refrigerator, this prevents any transference of food smells.

## The Freezer

### Freezing

The appliance can be used to freeze fresh food in the quantity specified on the rating plate. Freezing fresh food should always be done after proper preparing as follows.

Push the ACTION FREEZE button ("J") 4 hours before placing fresh food in smaller quantity or 24 hours before placing fresh food in bigger quantity into the appliance. The yellow light ("K") lit and the freezer temperature display ("G") shows an "A" symbol.

Put the previously frozen food - or some of it - to another basket or baskets. Put the fresh food into the lower basket, leaving enough space for airflow.

Run the appliance this way for 24 hours.

To exit from action freeze mode press the ACTION FREEZE button again. Should you not do so, after a while the freezer returns to automatic mode.

** Never freeze food in larger quantities than shown in the "Technical data" at the same time, otherwise food may not be thoroughly frozen.**

** Do not make ice during freezing preferably, because making ice reduces freezing capacity.**

## Removal of freezing baskets from the freezer

The freezing baskets have a limit stop to prevent their accidental removal or falling out. At the time of its removal from the freezer, pull the basket towards yourself and, upon reaching the end point, remove the basket by tilting its front upwards.

At the time of putting it back, slightly lift the front of the basket to insert it into the freezer. Once you are over the end points, push the baskets back in their position.

## Frozen Food Storage

When turning on the freezer for the first time or if the freezer has been out of use for some time, we advise you to run your appliance for at least 2 hours before storing frozen food.

Do not exceed the storage period indicated by the manufacturer.

Do not open the door frequently or leave it open longer than is necessary.

It is practical to replace frozen products into the basket(s) after freezing has finished. This will enable you to make room in the freezing compartment for other food. Intermediate freezing does not deteriorate foods already stored.

In large quantities of food are to be stored, remove the baskets except the lowest one from appliance and place food on the shelves.



### Important

*Do not put carbonated liquids in the freezer.*

*Ice lollies, if consumed immediately after removal from the freezer can cause a low temperature skin burn.*

*In the event of a power cut the food in the freezer will not be affected if the power cut is short and the freezer is full. Do not open the door. Should the food begin to thaw it must be consumed quickly and must not be re-frozen. (See Hints and Tips)*

*Do not remove items from the freezer if your hands are damp/wet, as this could cause skin abrasions or frost/freezer burns.*

## Thawing

Deep frozen or frozen food, prior to being used, can be thawed in the fridge or at room temperature, depending on the time available. Small food items may even be cooked from frozen, in this case cooking will take longer.

Any frozen food which is allowed to thaw accidentally should either be eaten as soon as possible, or thrown away. Alternatively, if the food is uncooked and has not been completely defrosted it can be cooked and then refrozen.



**Defrosted cooked food must never be refrozen.**

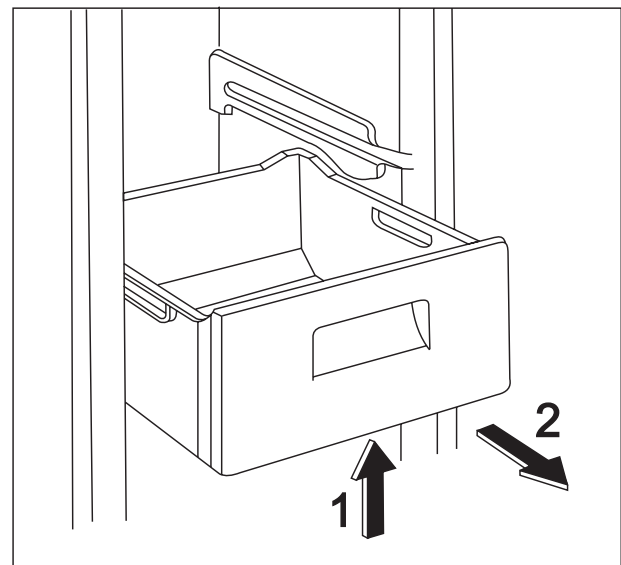
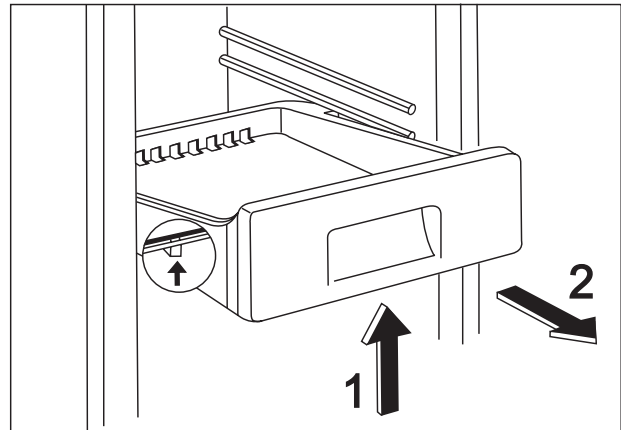

## To Make Ice Cubes

1. Fill the ice cube tray  $\frac{3}{4}$  full with cold water, place in the freezing compartment and leave to freeze.
2. To remove the cubes twist the tray or hold it under running water for a few seconds.

 *Never try to free an ice tray that is frozen to the freezer compartment by using pointed or sharp edged objects.*

# Hints & Tips

## Normal Operating Sounds

- You may hear faint gurgling or bubbling sounds when the refrigerant is pumped through the coils or tubing.
- When the compressor is on, the refrigerant is being pumped round and you will hear a whirring sound or pulsating noise from the compressor.
- A thermostat controls the compressor and you will hear a faint 'click' when the thermostat cuts in and out.

## Food Storage

To obtain the best performance from your freezer:

- Do not store warm food or evaporating liquid.
- Avoid buying frozen food if you cannot store it straight away. The use of an insulated container is advisable. When you arrive home, place the frozen food in the freezer immediately.
- Do not push food together too much, try to allow air to circulate around each item.
- Do not store often switch.
- Ensure that food placed in the freezer is dated and labelled and used in date order to ensure that food is consumed at its best.
- Lean food keeps better and longer than fatty food, salt reduces the storage time.
- Wrap the food in polythene or aluminium freezing bags or foil so that they adhere to the food and provide an airtight seal.
- Packaging which is swollen or has traces of refrozen water droplets on the pack could indicate that the product has not been kept at a suitable temperature and that it may have lost its original quality. Partially thawed food must not be refrozen, it must be consumed within 24 hours. Never exceed the storage times indicated by the manufacturer.

## Energy Saving Advice

- Do not install the appliance close to sources of heat, such as a boiler or radiator.
- Locate the appliance in a cool well ventilated room and make sure that the air openings of the appliance are not obstructed.
- Avoid unnecessary frosting in the cabinet by packing all foodstuffs into airtight packages before placing them in the freezer.
- Food which is to be frozen (when cool) should be placed in the fridge before being transferred to the freezer.
- Try to avoid keeping the door open for long periods or opening the door too frequently as warm air will enter the cabinet and cause the compressor to uncover food on unnecessarily often.
- Ensure there are no obstructions preventing the door from closing properly.

## In the Event of a Power Failure

If there is a power failure during the storage of frozen foods, keep the door closed. If the temperature within your freezer should rise, do not refreeze the food without checking its condition. The following guidelines should assist you:

**Ice Cream:** Once thawed should be discarded.

**Fruits & Vegetables:** If soft should be cooked and used up.

**Breads & Cakes:** Can be refrozen without danger.

**Shellfish:** Should be refrigerated and used up quickly.

**Cooked Dishes:** i.e. casseroles should be refrigerated and used up.

**Large Pieces of Meat:** Can be refrozen providing there are still ice crystals remaining within them.

**Small Joints:** Should be cooked and can then be refrozen as cooked dishes.

**Chicken:** Should also be cooked and refrozen as a fresh dish.

# Maintenance and Cleaning

 *Before any maintenance or cleaning is carried out you must DISCONNECT the appliance from the electricity supply.*

## Internal Cleaning

Clean the inside and accessories with warm water and bicarbonate of soda (5 ml to 0.5 litre of water).

Rinse and dry thoroughly.

 **NEVER use detergents, abrasive powders, highly perfumed cleaning products or wax polishes to clean the interior as these will damage the surface and leave a strong odour.**

## External Cleaning

Wash the outer cabinet with warm soapy water.

Once or twice a year dust the condenser (black grille) and the compressor at the back of the appliance with a brush or vacuum cleaner, as an accumulation of dust will affect the performance of the appliance and cause excessive electricity consumption.

## When the Appliance is not in Use

When the appliance is not in use for long periods, disconnect from the electricity supply, empty all foods and clean the appliance, leaving the door open to prevent unpleasant smells.

## HOLIDAY mode

The HOLIDAY mode is suitable when the refrigerator compartment is empty but there is foodstuff stored in the freezer.

The HOLIDAY mode is activated by pressing the "D" fridge temperature setting button several times. The display ("B") shows the letter "H".

To exit from the HOLIDAY mode press the "C" fridge temperature setting button.

**Important:** If the fridge compartment is off, the door must be closed in order that the freezer is working properly.

In this condition, the electronic control of the appliance functions automatically and periodically circulate the air to prevent unpleasant smells and humidity.

## Defrosting

Defrosting is automatic in this model.

### To Change the Light Bulb

Should the light fail to work you can change it as below:

Break the circuit of the appliance.

Press the rear hook (1) of the lampcover by a screwdriver and at the same time pull and rotate the cover in the direction indicated by the arrow (2). So the bulb can be replaced. (Bulb type: T25 Daylight 230-240 V, 25 W, E 14 thread)

After changing the bulb replace the cover, snap it in place and apply voltage to the appliance.

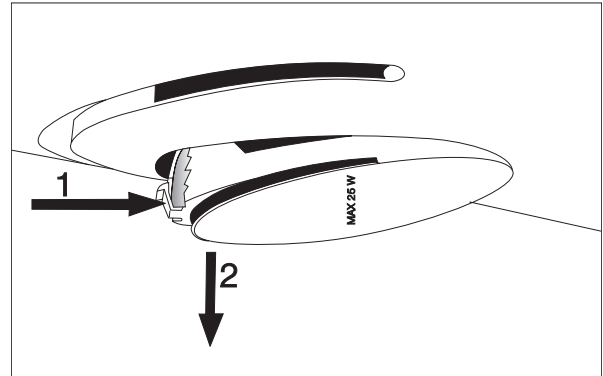

# Something Not Working

If the appliance is not working correctly, please carry out the following checks before contacting your local Service Force Centre.

Problem	Possible Cause	Solution
No power to the appliance	No power at the socket. There is a power cut. The fuse has blown.	Check there is power at the socket. Check there is not a power cut by checking the household lights. Check the fuse has not blown. Check the thermostat setting.
The temperature in the fridge or freezer is too high	The appliance is located in an unsuitable position. Temperature is set too low.	Check the ambient temperature is within the appliances operating limits of 10 °C to 32 °C. Check that the thermostat control knob is turned to the correct setting relative to ambient conditions.
The compressor runs continuously	Temperature is set at the wrong temperature. The door is open. Large quantities of food have been placed in the cabinet. The door has been opened too frequently. The air ventilation is obstructed.	Adjust the thermostat control knob. Close the door. Do not leave the door open longer than necessary. Check that the air ventilation is not obstructed.
The temperature in the fridge or freezer is too low	Temperature is set too cold.	Set the thermostat control knob to a warmer position.
Excessive frost and ice has built up	The door has been left open. Something is obstructing the door. The door gasket is dirty.	Check the door has not been left open. Check nothing is preventing the door from closing. Check the door gasket is intact and clean.
The appliance is noisy.	The appliance is not level.	Check if the appliance stands stable on the floor.

If after the above checks your appliance still does not operate correctly, contact your local Service Force Centre.

Please note that it will be necessary to provide proof of purchase for any in-guarantee service calls.

**In-guarantee customers should ensure that the above checks have been made, as the engineer will make a charge if the fault is not a mechanical or electrical breakdown.**

## Service and Spare Parts

In the event of your appliance requiring service, or if you wish to purchase spare parts, please contact your local Service Force Centre by telephoning:-

**08705 929929**

Your telephone call will be automatically routed to the Service Force Centre covering your post code area.

For the address of your local Service Force Centre and further information about Service Force, please visit the website at [www.serviceforce.co.uk](http://www.serviceforce.co.uk)

Before calling out an engineer, please ensure you have read the details under the heading "Something Not Working."

When you contact the Service Force Centre you will need to give the following details:

1. Your name, address and post code
2. Your telephone number
3. Clear and concise details of the fault
4. The model and serial number of the appliance (found on the rating plate)
5. The purchase date

**Please note that a valid purchase receipt or guarantee documentation is required for in-guarantee service calls.**

For Customer Service in Ireland please contact us at the address below:

Zanussi - Electrolux  
Electrolux Group (Irl) Ltd  
Long Mile Road  
Dublin 12  
Republic of Ireland

Tel: +353 (0)1 4090751

Email: [service.eid@electrolux.ie](mailto:service.eid@electrolux.ie)

## Customer Care Department

For general enquiries concerning your Zanussi - Electrolux appliance or for further information on Zanussi - Electrolux products, please contact our Customer Care Department by letter or telephone at the addresses below or visit our website at [www.zanussi-electrolux.co.uk](http://www.zanussi-electrolux.co.uk)

Major Appliances - Customer Care Department

Zanussi-Electrolux  
Addington Way  
Luton  
Bedfordshire  
LU4 9QQ

08705 727727 (\*)

\*calls to this number may be recorded for training purposes.



# Guarantee Conditions

We Zanussi - Electrolux undertake that if within 12 months of the date of the purchase this ZANUSSI - ELECTROLUX appliance or any part thereof is proved to be defective by reason only of faulty workmanship or materials, the company will, at our option repair or replace the same FREE OF CHARGE for labour, materials or carriage on condition that:

- The appliance has been correctly installed and used only on the electrical supply stated on the rating plate.
- The appliance has been used for normal domestic purposes only, and in accordance with the manufacturer's instructions.
- The appliance has not been serviced, maintained, repaired, taken apart or tampered with by any person not authorised by us.
- All service work under this guarantee must be undertaken by a Service Force Centre.
- Any appliance or defective part replaced shall become the Company's property.

Home visits are made between **8.30am** and **5.30pm Monday to Friday**. Visits may be available outside these hours in which case a premium will be charged.

## EXCLUSIONS

### This Guarantee does not cover:

Damage or calls resulting from transportation, improper use or neglect, the replacement of any light bulbs or removable parts of glass or plastic.

- Costs incurred for calls to put right an appliance improperly installed or calls to appliances outside the United Kingdom.
- Appliances found to be in use within a commercial environment, plus those which are the subject of rental agreements.
- Products of Zanussi - Electrolux manufacture which are not marketed by Zanussi - Electrolux.

The guarantee is in addition to your statutory and legal rights.

## EUROPEAN GUARANTEE

If you should move to another country within Europe then your guarantee moves with you to your new home subject to the following qualifications:

- The guarantee starts from the date you first purchased your product.
- The guarantee is for the same period and to the same extent for labour and parts as exists in the new country of use for this brand or range of products.
- This guarantee relates to you and cannot be transferred to another user.
- Your new home is within the European Community (EC) or European Free Trade Area.
- The product is installed and used in accordance with our instructions and is only used domestically, i.e. a normal household.
- The product is installed taking into account regulations in your new country.

Before you move please contact your nearest Customer Care Centre, listed below, to give them details of your new home. They will then ensure that the local Service Organisation is aware of your move and able to look after you and your appliances.

France	Senlis	+33 (0) 344 62 29 29
Germany	Nuremberg	+49 (0) 800 234 7378
Italy	Pordenone	+39 (0) 0434 39 4700
Sweden	Stockholm	+46 (0) 8 672 53 90
UK	Luton	+44 (0) 8705 727727
Ireland	Dublin	+353 (0)1 4090751

# Instructions for the Installer

## Technical data

Model	ZNB 404 W ZNB 404 S
Gross capacity (l)	Refrigerator: 251 Freezer: 122
Net capacity (l)	Refrigerator: 240 Freezer: 109
Width (mm)	595
Height (mm)	2010
Depth (mm)	632
Energy consumption (kWh/24h) (kWh/year)	1,12 409
Energy class, according to EU standards	A
Freezing capacity (kg/24h)	10
Rising time (h)	16
Rated current (A)	0,6
Noise Lc (dB)	42
Weight (kg)	77
Number of compressors	1

## Installing the appliance

### Transportation, unpacking

The appliance and the interior fittings are protected for transport.

- Remove all packaging and any adhesive tape.
- Any remnants of adhesive can be removed using white spirit.
- After transportation the appliance must not be switched on for 2 hours. This is to allow the refrigerant to settle.

### Cleaning

Clean the accessories and the inside of the appliance with warm water and bicarbonate of soda (5 ml to 0.5 litres of water). Rinse and dry thoroughly.

*Do not use detergents, abrasive powders, highly perfumed cleaning products, wax polishes or cleaning products containing bleach or alcohol.*

## Location

The appliance should be positioned in a well ventilated, dry room.

Energy use is affected by the ambient temperature.

The appliance should therefore:

- not be installed next to radiators, cookers or other sources of heat
- only be installed at a location where the ambient temperature corresponds to the climate classification, for which the appliance is designed.

The climate classification can be found on the rating plate.

The following table shows which ambient temperature is correct for each climate classification:

Climate Classification	Ambient Temperature
SN	+10 to +32 °C
N	+16 to +32 °C
ST	+18 to +38 °C

In the bag of the accessories there are two spacers which must be fitted in the two top corners.

Slacken the screws and insert the spacer under the screw head, then re-tighten the screws.

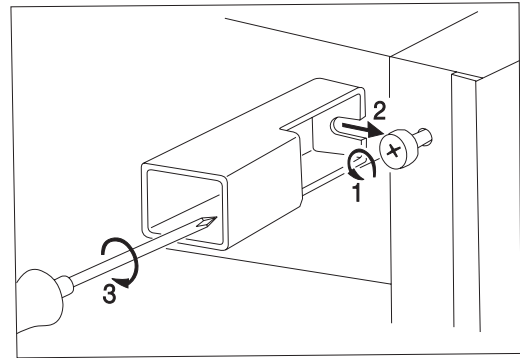

## Levelling the Appliance

When positioning the appliance ensure that it stands level. This can be achieved by two adjustable feet at the bottom in front.

Do not stand the appliance next to a source of heat such as a radiator or cooker.

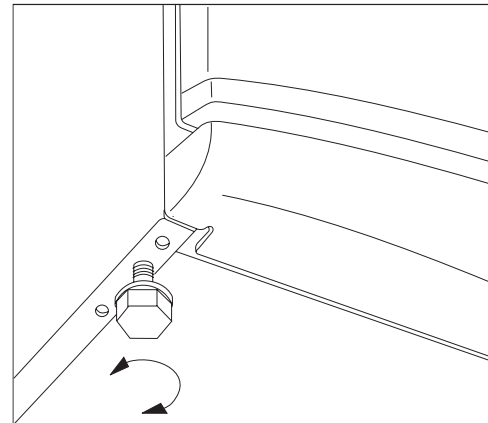

## Ventilation Requirements

The appliance must have adequate ventilation to ensure correct operation.

Diagram shows the ventilation requirements when installed:

- A Under a cupboard.
- B When freestanding

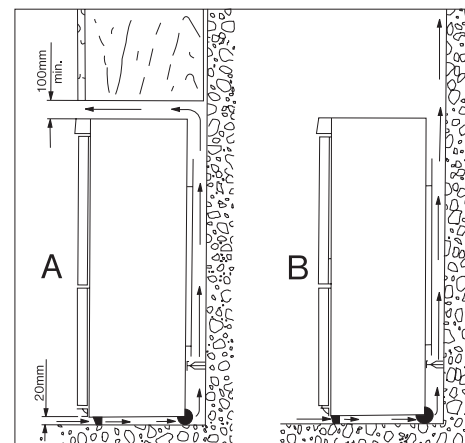

## Removal of glass shelf blockers from the product

The glass shelf blockers are used to fix the shelves into position during product transport. These blockers will not be necessary for the further operation of the product.

Open the refrigerator door as wide as possible.

1. Slide the blocker tabs to the front of the shelf.
2. Lift the back of the shelf from its nest and then pull it towards yourself by tilting its front upwards/downwards.
3. Remove the blocker tabs.

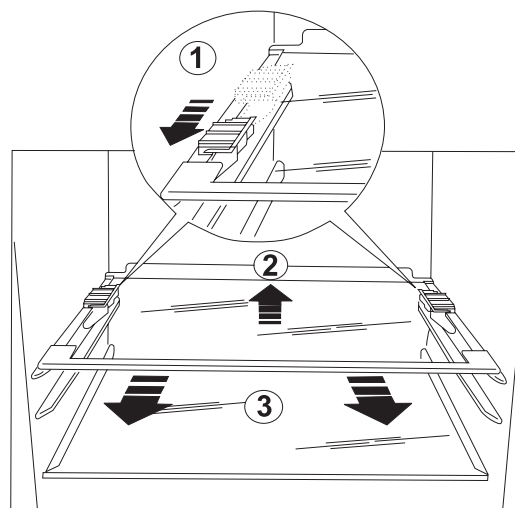

## Door reversal

Should the location demand it, door-opening direction can be refitted from right-handed to left-handed.

Appliances are supplied right-handed.

Following operations are to be done on the basis of figures and explanations:

1. To perform the operations listed below it is recommended to ask another person for help who safely can hold the doors while performing the operations.
2. Disconnect the appliance from the electricity supply.
3. Open the doors and dismount the double door hinge (a, b) by removing the screws (2 pieces) (c). (fig.2)
4. Take off the double door hinge (a, b, c) by gradually removing it from the cabinet, slightly tilting both doors. Do not forget to remove the plastic spacer (b) under the hinge. (fig.2)
5. Take off the refrigerator door by pulling it slightly downwards.
6. Take of the freezer door by pulling it slightly upwards.
7. Remove the plug on the upper side of the refrigerator door and put it to the other side.
8. Remove the plug on the upper side of the freezer door and put it to the other side.
9. Unscrew the top door hinge pin (d) of the refrigerator door then screw it back on the other side. (fig.1)
10. Remove the plugs (u) at the bottom of the appliance. (fig.3)
11. Remove the lower hinge (e) by removing its screws (s) and mount it on the other side. (fig.3)
12. Unmount the lower hinge pin (f) and its washer (h) and mount them into the other hole of the lower hinge. (fig.3)
13. Replace the plugs (u) on the other side.
14. Remove the covering pins (3 pieces) (n, k) of the double door holder on the left side and put them to the other side. (fig.2)
15. Fit the pin of the double door hinge (m) into the left hole of the freezer door. (fig.2)
16. Fit the freezer door to the lower door hinge pin (f). (fig.3)
17. Fit the refrigerator door to the upper door hinge pin (d) then slightly tilting both doors fit the pin of the double door hinge (m) into the left hole of the refrigerator door.
18. Opening both doors fix the double door hinge onto the left side using the screws (2 pieces) (c). Do not forget to replace the plastic spacer (b) under the hinge. Be careful that the door edges are parallel with the edge of the mantle.

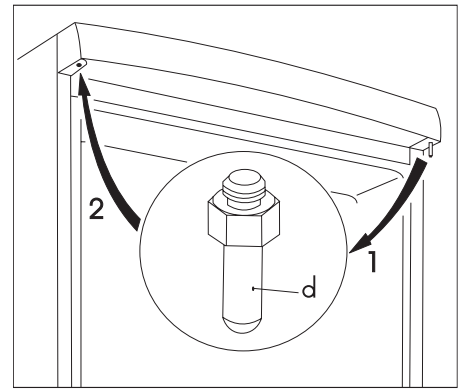

fig. 1.

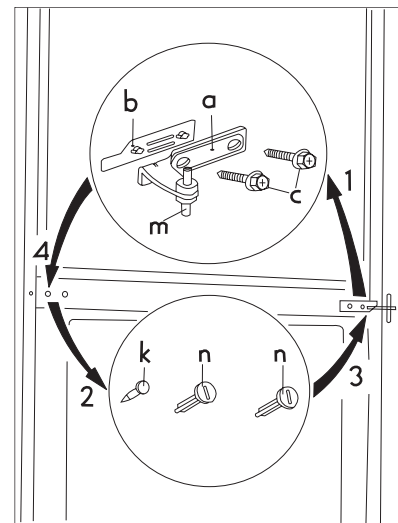

fig. 2.

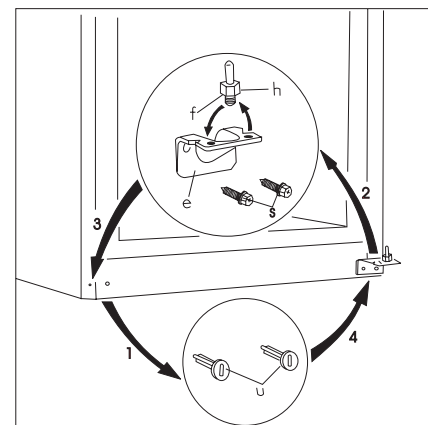

fig. 3.

19. Put the appliance into its location, ensure it is level, and plug it into the mains supply.

In case you do not want to perform the procedures above, call the Service Force Centre.

Technicians will make a charge for door reversal.



**Important**

After completion of the door reversing operation, check that the door gasket adheres to the cabinet. If the ambient temperature is cold (i.e. in Winter), the gasket may not fit perfectly to the cabinet. In that case, wait for the natural fitting of the gasket or accelerate this process by heating the part involved with a normal hairdryer on a low setting.

# Electrical Connection

 Any electrical work required to install this appliance should be carried out by a qualified electrician or competent person.

*This appliance must be earthed.*

**The manufacturer declines any liability should these safety measures not be observed.**

## Electrical Requirements

Before switching on, make sure the electricity supply voltage is the same as that indicated on the appliance rating plate.

The appliance is supplied with a 13 amp plug fitted. In the event of having to change the fuse in the plug supplied, a 13 amp ASTA approved (BS 1362) fuse must be used. Should the plug need to be replaced for any reason. The wires in the mains lead are coloured in accordance with the following code:

Green and Yellow: Earth  
Blue: Neutral  
Brown: Live

The wire coloured green and yellow must be connected to the terminal marked with the letter "E" or by the earth symbol  $\oplus$  or coloured green and yellow.

The wire coloured blue must be connected to the terminal "N" or coloured black.

The wire coloured brown must be connected to the terminal marked "L" or coloured red.

**Upon completion there must be no cut, or stray strands of wire present and the cord clamp must be secure over the outer sheath.**

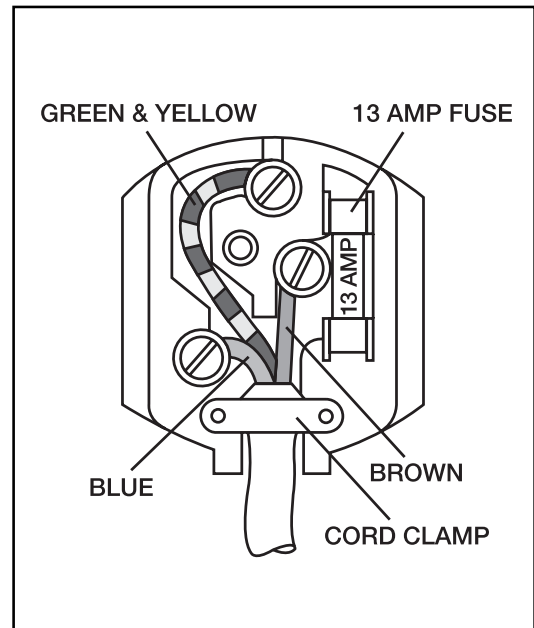

 **Important!**

**The plug must still be accessible after the appliance has been installed.**

**The appliance should not be connected to the electrical supply by means of an extension cable.**

**In case that the electrical cable has to be replaced, please contact your local Service Force Centre.**

 **Warning!**

**A cut off plug inserted into a 13 amp socket is a serious safety (shock) hazard. Ensure that it is disposed of safely.**

 This appliance complies with the following E.E.C. Directives:

- **73/23 EEC** of 19.02.73 (Low Voltage Directive) and subsequent modifications,
- **89/336 EEC** of 03.05.89 (Electromagnetic Compatibility Directive) and subsequent modifications.
- **96/57 EEC** - 96/09/03 (Energy Efficiency Directive) and its subsequent amendments

# Storage time chart

Time and method of storage of fresh foods in the refrigerator

Foods	Storage time in days							Method of packaging
	1	2	3	4	5	6	7	
Raw meat	X	X	x	x	x			cling film, airtight
Cooked meat	X	X	X	x	x	x		dish covered
Roasted meat	X	X	X	x	x			dish covered
Raw minced meat	X							dish covered
Cooked minced meat	X	X	x	x				dish covered
Cold cuts	X	X	x	x				cling film, cellophane, grease-proof paper
Fresh fish	X	x	x					cling film, airtight
Cooked fish	X	X	x	x				dish covered
Tinned fish, open	X	x	x					dish covered
Fresh chicken	X	X	X	x	x	x		cling film, airtight
Fried chicken	X	X	X	x	x	x		dish covered
Fresh duck, goose	X	X	X	x	x	x		cling film, airtight
Roasted duck, goose	X	X	X	X	x	x	x	dish covered
Butter unopened	X	X	X	X	X	X	X	original packaging
Butter opened	X	X	x	x	x	x	x	original packaging
Milk	X	X	X	x	x			original packaging
Cream	X	X	x	x				plastic box
Sour cream	X	X	X	X	x	x	x	plastic box
Cheese (hard)	X	X	X	X	X	X	X	aluminium foil
Cheese (soft)	X	X	X	X	x	x	x	cling film
Egg	X	X	X	X	X	X	X	
Spinach, sorrel	X	X	x	x				cling film
Green peas, green beans	X	X	X	X	x	x	x	cling film
Mushroom	X	X	x	x	x			cling film
Carrot	X	X	X	X	X	X	X	cling film
Tomato	X	X	X	X	X	X	X	cling film
Cabbage	X	X	X	X	X	x	x	cling film
Fruits (Strawberry, raspberry, etc.)	X	X	X	x	x			cling film
Tinned fruits opened	X	X	X	x	x			dish covered
Cakes filled with cream	X	X	x	x				dish covered

## Notation:

- X** recommended storage time
- x** maximum recommended storage time

© Electrolux plc 2006

ELECTROLUX HOME PRODUCTS OPERATIONS EUROPE

 **From the Electrolux Group. The world's No.1 choice.**

*The Electrolux Group is the world's largest producer of powered appliances for kitchen, cleaning and outdoor use. More than 55 million Electrolux Group products (such as refrigerators, cookers, washing machines, vacuum cleaners, chain saws and lawn mowers) are sold each year to a value of approx. USD 14 billion in more than 150 countries around the world.*